

Dri Heater

For use with Drimaster, PIV
and derivative Ventilation Units

Installation Guide

 The EMC Directive
 89/336/EEC
 With modification
 92/31/EEC
 The Low Voltage
 directive 73/23/EEC

Dri Heater

Designed to operate with the NuAire range of Drimaster, PIV and derivative ventilation units.

Installation in Drimaster and Drimaster 2000

Installation must be completed by competent persons, in accordance with good industry practice and the provision of the electrical supply and the connection of the unit to the mains must be carried out by a qualified electrician.

1. To install the heater temporarily remove the flexible ducting from the Drimaster.
2. Remove the top casing screw in the Drimaster in order to open/part the casing sides. (see Figure 2).

3. Note the location slots at the end of the circular heater assembly and offer this end into the open circular aperture in Drimaster. Locate the duct slots behind the units internal vertical side mouldings and ensure plate goes under clip on fan outlet.

4. Close the casing, replace and tighten the screw clamping the heater in position.

5. Using the nylon tie supplied, re-connect the flexible ducting and the unit filters.

Installation in the PIV unit

Fit the end of the circular heater assembly inside the spigot on the PIV casing. Ensure heater is horizontal and drill three holes. Secure with screws.

Figure 1. Dri Heater unit

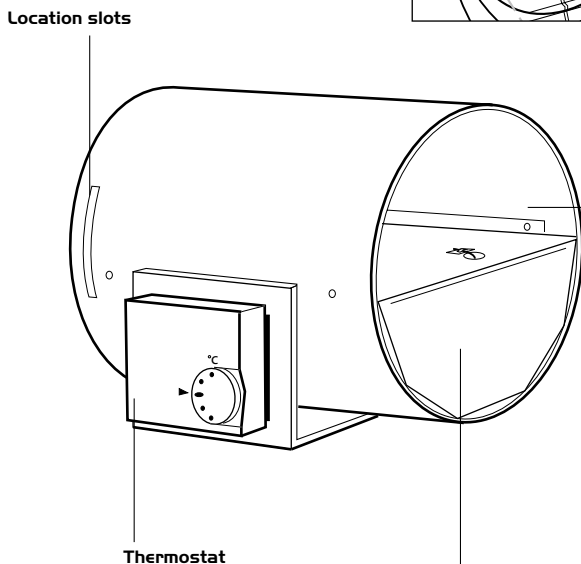

Figure 2. Drimaster Unit

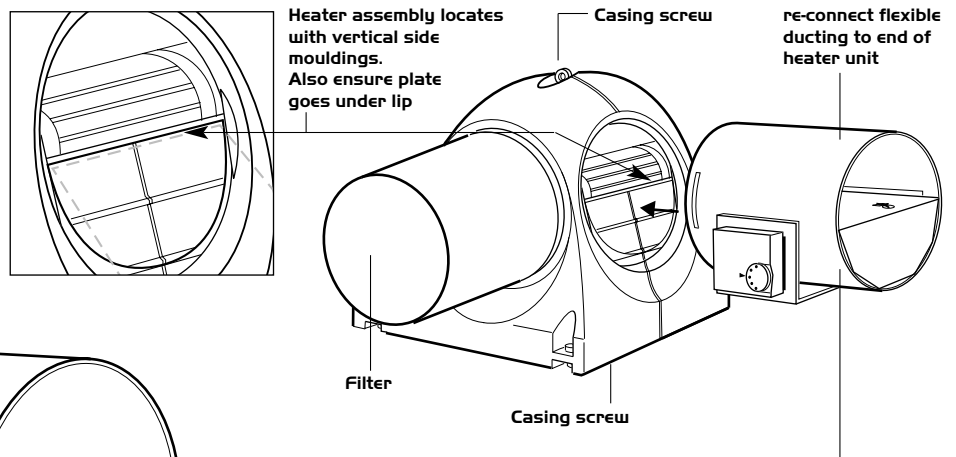
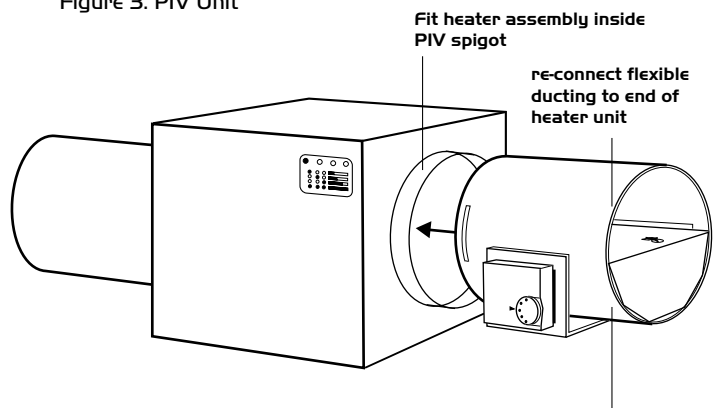

Figure 3. PIV Unit



Electrical Connection

Open the thermostat unit by removing the adjuster knob to expose the cover retaining screw.

The mains supply cable (by others) should be routed through the rear of the thermostat and connected to the appropriate terminals. See figure 4.

Note: the thermostat wiring diagram is duplicated inside the thermostat covers.

Refit the cover and adjustment knob and set the adjustment knob to 10°C.

Figure 4.
Electrical connections

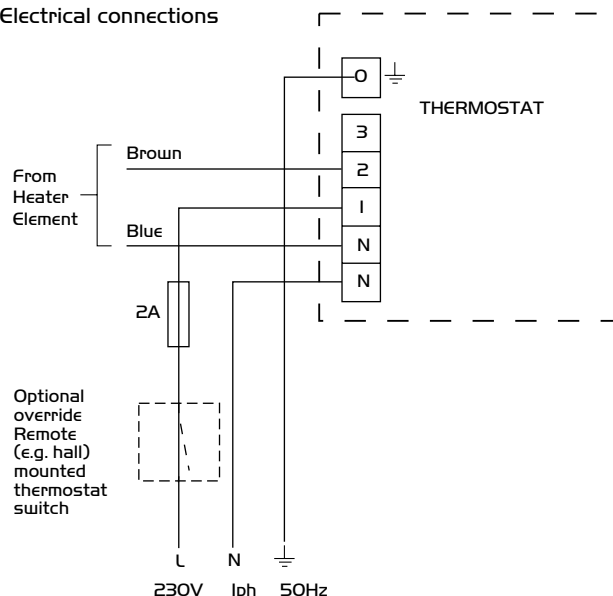

Wiring diagram for automatic operation via the heater thermostat or optional remote override switch.

Adjusting the Thermostat

The occupier will normally require the heater to activate when the loft temperature falls below a predetermined point.

We recommend that the thermostat knob be set at 10°C.

Note: the thermostat should not be set any higher than 19°C.

IMPORTANT

Ensure the fan is running before operating the heater.

If the heater should trip out the power should be isolated for several minutes to allow the unit to reset the thermal trip.

The heater is rated at 500 watts and should be connected to a suitably rated power supply via a switched fused spur (by others).

Maintenance

The unit does not require any maintenance. However, for optimum performance, it is advisable to remove any accumulated dust with a low power vacuum cleaner.

NOTE: Installation and Maintenance of the equipment must be as directed in the instructions provided with the unit.

3 Year Warranty

The 3 year warranty starts from the day of delivery and includes parts and labour for the first year.

The remaining 2 years covers replacement parts only.

This warranty is conditional on planned maintenance being undertaken.

Service Enquiries

Nuaire can assist you in all aspects of service. Our service department will be happy to provide any assistance required, initially by telephone and if necessary arrange for an engineer to call.

Telephone 029 2085 8585
Fax 029 2085 8586